

Subject: Cylinder Head Inspection and Installation

Affected engines: All engine models:

L 1700
L 2000
L 2400

Cylinder Head Removal

1. Remove induction and exhaust tubing as well as spark plugs. On engines with liquid cooled cylinder heads drain coolant and remove coolant pipes.
2. Remove cylinder head cover.
Use appropriate lever to lift cover, if necessary.
Remove clamp.
3. Remove nuts of rocker shafts. Remove rocker shafts. Pull out push-rods. Check push-rods for warpage – max. 0.3 mm. Disassemble rocker shafts and check any parts for wear.
4. Check valve shaft projecting length by means of measuring device (T/N 803.001.130.000)

Wear limits for inlet and outlet valves:

Air cooled cylinder heads: 24,00 mm

Liquid cooled cylinder heads: 23,30 mm

Caution:

Once the wear limit has been reached, the cylinder head must be replaced.

If the wear limits have not yet been reached, the cylinder head can be disassembled.

Note:

If the measurement result for air-cooled cylinder heads is 24.50 mm and for liquid-cooled cylinder heads 23.80 mm, the valve shaft projection length must be checked every 100 hours.

5. Remove cylinder head nuts.

Caution: Always remove and install cylinder heads in pairs in order to avoid bracing of the crankcase.

Remove cylinder heads and putrid protection tubes.

Check protection tubes for cracks and external damage and replace as necessary. Push-rod tubes for air cooled engines must be adjusted to dimension "a" before installation by lengthening the bellows. For engines with liquid cooled cylinder heads the telescopic push-rod tubes must be free to move.

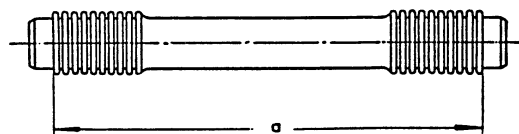

Length "a" for	L 1700 EB	193 to 194 mm
	any other L 1700 and L 2000	190 to 191 mm
	L 2400	195 to 196 mm

Cylinder head inspection

1. Remove valves.
Push down valve popped or valve rotating device and remove valve cotter pieces. Release springs and remove them. Pull out valves.
Caution: Mark valves to avoid mixing them up.
Check valve springs for corrosion marks and replace as necessary. Check valve seats and valve shaft for wear and rework valve seats or replace as necessary.
2. Clean and check cylinder heads.
Check cylinder for cracks in the combustion chambers and exhaust passages as well as for leakage's at the sealing surfaces. Replace damaged cylinder heads. Check spark plug thread and stud bolts for damage and tight fit. If necessary, repair spark plug thread by using Heli-Coil inserts.
3. Check valve guides.
Insert valve into guide and slip it in until the shaft end is flush with the end of the valve guide. In the position measure the tilt clearance of the valve in the guide by means of a dial gauge. When measuring, the feeler of the dial gauge has to be flush and centred with the valve poppet. The max tilt clearance must not exceed 0,8 mm in any direction.

Assembling of Cylinder Head

1. Oil valve shafts and inserts valves into valve guides.
2. Install valve springs.
Caution: The lengths of the not-installed valve springs are as follows:
 - air cooled cylinder heads without valve rotating device ca. 52 mm,
 - air cooled cylinder heads with valve rotating device ca. 49 mm,
 - liquid cooled cylinder heads ca. 47,5 mm,**Install valve spring with the tighter windings pointing towards the cylinder head.**
3. Attach valve spring retainer or valve turning device respectively and clamp springs. Insert valve cotters.
Caution: When using normal valve spring retainers insert hardened valve cotters, when using valve turning devices use soft cotters. Characteristic feature: hardened valve cotters may be turned easily when attached to the valve shaft grooves and have a ground split line whereas soft cotters include the whole valve shaft and jam. The split line of soft cotters is not ground.
4. Release valve springs.

Cylinder Head Installation

1. Preassemble cylinder heads.
 - **Air cooled cylinder heads:** Install air cooled cylinder head onto the studs. Insert pushrod protection tubes using new gaskets. Align protection tubes so that the seam is upside. Move cylinder heads to be in contact with the cylinders.
 - Cylinder heads fastened with washer, nut and safety nut:
Wet washers of lower stud bolts on one side with REINZOSIL SI 300 and mount with wetted side to the cylinder head. Wet stud bolts threads with REINZOSIL SI 300. Wet nuts of stud bolts at the unmarked (strength grade) seating face with REINZOSIL SI 300 and mount with wetted side to the cylinder head.
Note: All surfaces that have contact with the sealant, must be free of grease or oil.
 - Cylinder heads fastened with flange nut:
Apply REINZOSIL SI 300 sealing compound to the threads of the studs and the contact area of the cylinder head nuts. Mount nuts.
 - **Liquid cooled cylinder heads:** Install cylinder head onto the studs. Push the cylinder head towards the engine until it contacts with the cylinders. Apply REINZOSIL SI 300 sealing compound to the threads of the studs and the contact area of the cylinder head nuts. Mount nuts.
Note: All surfaces that have contact with the sealant, must be free of grease or oil.

2. Prestrain cylinder head nuts.

Caution: Care for proper seating of the gaskets between push-rod protection tubes and crankcase or cylinder head respectively.

Torquing sequence according to the following figure (figures in brackets) Prestrain torque 10 Nm.

3. Tighten cylinder head nuts.

Newer series L 1700, L 2000 engines and all engines of series L 2400 are equipped with so-called antifatique screws for cylinder head attachment. Antifatique screws have a much smaller shaft diameter than thread diameter. So they can be identified easily. Older bolts have the same diameter over the entire length.

Torquing procedure, old version: Torque nuts by torque wrench. For torques see below .

Torquing sequence according to the picture below – figures without brackets.

Torques:

L 1700	10 mm	32 Nm
L 1700	8 mm	25 Nm
L 2000	8mm	25 Nm

Torquing procedure, new version: Torque nuts by torque wrench in two steps. Torques see below. Torquing sequence according to the picture below – figures without brackets.

Torques:

	1.step	2.step
L 1700, L 2000 - 10 mm	20 Nm	35 Nm
L 2400 all	25 Nm	40 Nm

Caution: Ignoring the torquing instructions may cause engine damage.

Mount and tighten safety nuts on air cooled cylinder heads fastened with washer, nut and safety nut.

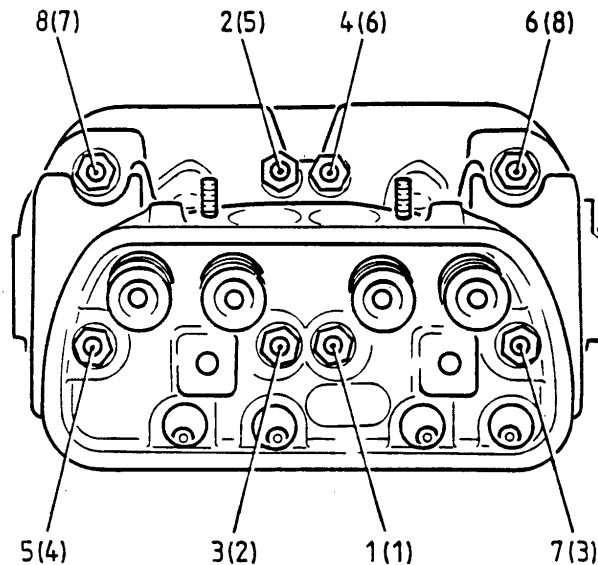

4. On engines wit liquid cooled cylinder heads fit telescopic push-rod tubes with new gaskets and insert them into location. Check seating of gaskets.

5. Insert push-rods. Assemble rocker shafts and preattach them to the cylinder head with nuts. Mount rocker shaft brackets so that the slotted side is facing upside.

Check position of valve clearance set-screws relative to the valve shaft.

- At cylinder heads with valve turning devices, the set-screws must be centred on the valve shaft. If necessary, readjust rockers on the rocker shaft by means of spacing washers.
- At cylinder heads without valve turning devices, the set-screws must hit the valve shaft 1,0 to 1,5 mm off-centre (see next picture). If necessary, readjust rockers on the rocker shaft by means of spacing washers.

Caution: On air cooled engines with valve rotating devices, crank the engine manually and check that the rockers do not touch the valve turning devices. If this is the case, the rocker shaft brackets have to be shimmed by washer plates P/N 170.055.270.

Note: If the adjustment range of the valve clearance set-screws is no sufficient, the rocker shaft brackets must be shimmed.

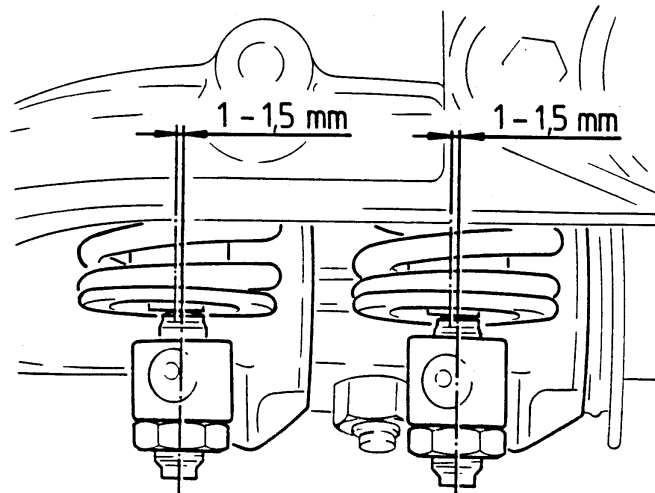

6. Remove rocker shafts. On air cooled cylinder heads, having a rectangular groove around the stud in the boss for the rocker shaft brackets, new seal rings have to be used. On air cooled cylinder heads, having no rectangular groove, the rocker shaft brackets and their bosses at the cylinder head have to be wetted with REINZOSIL SI 300. On engines with liquid cooled cylinder heads do not need sealant on those bosses.
Attach rocker shafts and tighten them. Torque 25 Nm.
On engines with liquid cooled cylinder heads check seating of push-rods prior to torquening the rocker arm assembly by rotating the push-rod
Caution: Use nuts for strength grade 10 only.
7. Check valve clearance and readjust as necessary. Valve clearance for all valves is 0.2 mm.
Untighten check-nut and turn set-screw until feeler can be moved slightly "sucking". Tighten check-nut set-screw in this position. Check valve clearance and adjust again if necessary.
8. Install clamp of cylinder head cover and mount cylinder head cover.
Use new gaskets for valve cover. Glue gasket to cover with CURIL-C sealing compound.
9. Install induction and exhaust tubing. On engines with liquid cooled cylinder heads reassemble coolant pipes and fill-up with coolant.
Use new gaskets.
10. Install spark plugs and ignition harness.
Torque spark plugs:
 - on air cooled cylinder heads to 25 Nm,
 - on liquid cooled cylinder heads to 20 Nm.

Notice:

This document has been translated to the best of our knowledge. In case of doubt, however, only the German original shall be considered as authoritative.