

**Subject:** Cylinders and Cylinderheads on repaired or exchange engines

**Affected engines:** All engines of the following types:

**L 1700**  
**L 2000**  
**L 2400**

As from now, engines which are fitted with reworked cylinder heads and/or cylinders, are fitted with shims (C) under the cylinders. Reworked cylinders and cylinder heads are marked with up to three asterisks (\*). The cylinder heads are marked near the exhaust flange in the vicinity of the part number (A), the cylinders are marked at the base near the cylinder number (B).

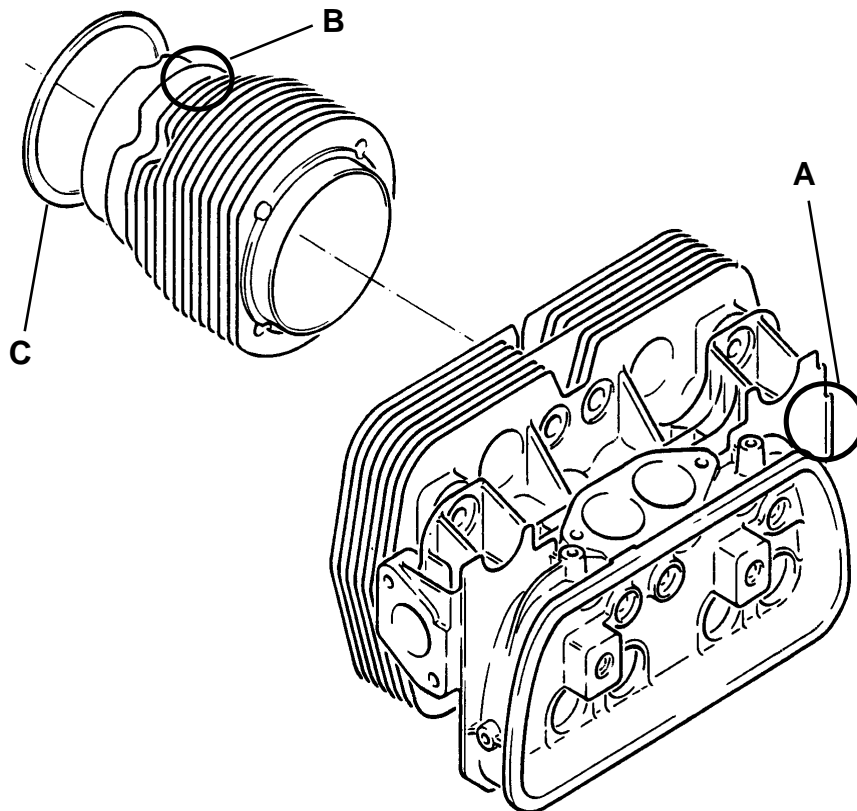

The two adjoining cylinders must have the same rework stage (number of asterisks). The shims are coated with sealant (REINZOSIL SI 300) on both sides.

**Note: All surfaces that have contact with the sealant, must be free of grease or oil.**  
For the required thickness of the shims refer to the following tables.

### L 2000 and L 2400 series:

Markings		Shim thickness (mm)
cylinder head	cylinder	
-	*	0,50
-	**	0,75
-	***	1,00
*	*	1,00
*	**	1,25
*	***	1,50
**	*	1,25
**	**	1,50
**	***	1,75
***	*	1,50
***	**	1,75
***	***	2,00
*	-	0,50
**	-	0,75
***	-	1,00

### L 1700 series:

always receives new cylinders for repair and overhaul. Therefore only reworked cylinder heads are considered for this series.

Markings		Shim thickness (mm)
cylinder head	cylinder	
*	-	0,50
**	-	0,50
***	-	0,75

For information regarding the assembly please refer further to the applicable maintenance instructions or the repair manual

**Notice:**

This document has been translated to the best of our knowledge. In case of doubt, however, only the German original shall be considered as authoritative.